



IP-DXL Display Control Center

Product Manual



Contents

1. Overview	3
2. Installing the IP-DXL	4
3. Front Panel Operation.....	4
4. Front Panel Setup Menus.....	5
5. Rear Panel Connections	6
6. Setup Notes.....	6
7. RS-232/Telnet Bidirectional ASCII Serial Communication Protocol.....	8
8. Bidirectional Serial Commands	8
9. iCC-Net Control Overview	10
10. Building an IPTV Based Control System	10
11. Compatible IPTV Control System Components.....	11
12. IPTV System Control Data Flow Examples	12
13. iCC-Net Display Control Protocol	14
14. Common iCC-Net Commands	16
16. Display Express Lite Control Software.....	17
17. RKU Universal Rack Mount Kit	20
18. Specifications	21
19. Safety Instructions and Warranty	22

1. Overview

The IP-DXL Display Control Center is an integral component of the iCC-Net IPTV display control solution. The unit may be used as an interface for sending one-way control commands to multiple QIP-D and QIP-DVX decoder/controllers for decoder and display control.

The unit has an on-board web server that hosts the Display Express Lite control software. The software can function as the user interface for independent control of the decoder/controllers and their connected displays. The software can be accessed from the web browser of any device. The control functions include but are not limited to power, volume, and source channel selection.

The unit may also receive iCC-Net protocol control strings from a Display Express server PC or a third-party control system processor. iCC-Net control commands may be received by TCP over the Ethernet connection, RS-232 via the DB-9 connector, or USB virtual com port. Each string is validated and sent out as a UDP directed broadcast data packet to the decoder/controllers.

An on-board web server hosts the Display Express Lite control software. The software is accessible using an internet browser from a tablet, smart phone, or computer. The software is easy to configure and may be used for control of up to 128 display controllers or tuner/controllers. Control functions include power on/off, volume and channel selection from up to 32 source channels.

The IP-DXL is primarily designed for use with the QIP-D and QIP-DVX decoder/controllers, but it may also be used to send limited control commands to the 232-ATSC 4K and ATSC-SDI 4i HDTV tuners.

Features

- For insertion of ICC-Net control into IPTV distribution system
- One-way control for over 4000 IPTV decoders and displays over Ethernet network
- Compatible with QIP-D and QIP-DVX decoder/controllers
- Compatible with 232-ATSC 4K and ATSC-SDI 4i tuners for tuner control only
- iCC-Net control data sent as UDP directed broadcast data packets over IP
- Display Express Lite control software accessible from built-in web server
- Accepts iCC-Net control commands from Display Express Server PC or third-party control system processor
- Receives iCC-Net serial control commands via RS-232 com port, USB virtual com port, or TCP
- Front panel LCD display with 6-button keypad for configuration and status monitoring
- Front and rear panel USB virtual com ports
- Firmware updatable over RS-232 com port, USB virtual com port, or Ethernet
- Convenient 1 RU half width chassis with rack mount kit included.

2. Installing the IP-DXL

The IP-DXL Display Control Center may be placed freestanding on a suitable surface or installed in a standard EIA 19" equipment rack with the included RKU rack mount hardware kit. The RKU rack mount hardware facilitates mounting of IP-DXL in one rack space by itself side by side with another Contemporary Research half rack width product.

3. Front Panel Operation



Front Panel Menu

Configuration settings for AV setup, System setup and Network setup are available on the front panel LCD display.

- Press the red **SETUP** button to access the front-panel menus
- Press the **Left/Right** arrows to step through each configuration menu category
- Press **SELECT** to enter the menu
- Press the **Up/Down** arrows to view the settings
- Press the **Left/Right** arrows to step through the setting options
- Press **SELECT** to save the changes for each menu
- Press **SETUP** to back out of a menu or exit configuration settings

USB Service

USB mini-B jack virtual com port for control, configuration, and firmware updates.

LCD Display Status Indicators

232	Rx or Tx will flash indicating RS-232 data activity
USB	Rx or Tx will flash indicating front panel or rear panel USB data activity
IP	Rx or Tx will flash indicating IP data activity
N	iCC-Net status, blinks once per second indicating transmission of iCC-Net "heartbeat" data
C	Command indicator will flash indicating transmission of valid iCC-Net command
E	Not Applicable

4. Front Panel Setup Menus

System	<i>Factory Defaults settings are shown in Bold</i>
Baud Rate	2400 4800 9600 19200 38400 115K
Pnl Lockout	None Setup <i>Press Setup and Right simultaneously to temporarily unlock</i>
Backlight	1 – 10
LCD Contrast	1 – 9
Fact Dfault	Y N
Firmware	<i>Right or Left arrow scrolls through firmware versions.</i> <i>Example:</i> IC-IP-DXL 3.04 — System Firmware Bootloader V1.00 Board Rev C – Hardware version
Network	
IP Address	192.168.1.251
IP Mode	Static DHCP
Gateway	192.168.001.001
Subnet Mask	255.255.255.000
MAC/SN	0:14:C8:16:xx:xx
UDP Relpy	On Off
Command	
Power All	On Off <i>Sends Power command to all display controllers</i>
Volume All	Mute Low Medium <i>Sends Volume level command to all display controllers</i>
Send IR Typ	Dev#:xxxx Type:xx <i>Sends display type command to specified display controllers. For QIP-DVX only. Refer to QIP-DVX product manual for display type codes.</i>
Send 232 Typ	Dev#:xxxx Type:xx <i>Sends display type command to specified display controllers. For QIP-D and QIP-DVX only. Refer to QIP-D or QIP-DVX product manual for display type codes.</i>

5. Rear Panel Connections

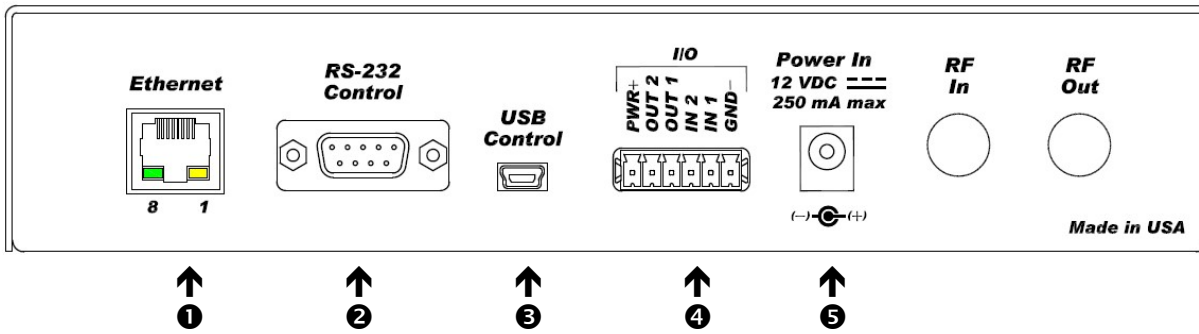

❶ Ethernet

RJ-45 jack, 100Mbps for control, web page access, configuration, and firmware updates

❷ RS-232 Control

DB-9 male RS-232 data link for control, configuration, and firmware updates

❸ USB Control

USB mini-B jack virtual com port for control, configurations, and firmware updates

❹ I/O

Logic control port 6-pin captive screw terminal

1 – PWR+	Power, 12 VDC, 250 mA max (using the included 500 mA power supply)
2 – OUT2	Output 2
3 – OUT1	Output 1
4 – IN2	Input 2
5 – IN1	Input 1
6 – GND-	Ground

❺ Power In

2.1 mm coaxial jack (inside center conductor positive), 11 to 18 VDC, 12 VDC typical, 250 mA maximum

6. Setup Notes

Interfacing with a Control System

The unit may receive iCC-Net command strings from a Display Express server PC or a third-party control processor. The command strings may be received at the following interfaces.

- Ethernet TCP at port 2728
- RS-232 via the DB-9 serial port
- RS-232 via front or rear USB virtual com port

Only one TCP socket is supported. The buffered data bus allows for commands to be received concurrently from any of the interfaces.

Web Pages

The IP-DXL has a web server with web pages for the Display Express Lite control software and for configuration of the unit. The web pages are password protected by default. Open a web browser and enter the IP address of the IP-DXL into the address bar to access the web pages. The unit's current IP address may be displayed on the front panel by holding the **Setup** button.

Display Express Lite Embedded Control Software

The ICE-HE-DXL includes the Display Express Lite web pages. Display Express Lite supports basic control of power, volume, and channel selection for any combination of up to 128 IPTV decoder/controllers. Simple on/off with channel selection scheduling is also supported.

IP Network Settings

The IP Address, Default Gateway, and Subnet Mask may be set in the front panel Network menu or via RS-232 command. The current IP address may be displayed on the front panel by holding the Setup button. The default IP address is 192.168.1.251. Changes to any of network settings require a power cycle or reboot.

RS-232

The DB-9 RS-232 serial port may be used for control, configuration, and firmware updates. The baud rate settings apply to the DB-9 RS-232 serial port and the rear panel USB virtual com port. Baud Rate settings are available in the front panel System menu or may be changed via RS-232 or Telnet serial command. The default baud rate is 19,200. Changes to the baud rate setting are instantaneous and no power cycle or reboot is required.

USB Virtual Com Ports

The front and rear panel USB virtual com ports may be used for control, configuration, and firmware updates. Windows 10 or 11 will automatically load the appropriate driver. The baud rate setting applies to the rear panel USB port. The baud rate for the front panel USB virtual com port is fixed at 115.2K.

I/O Port

Inputs may accept a 0-24 VDC control voltage or contact closure to ground. A closed contact closure creates a logical low, an open contact closure creates a logical high.

Outputs are open collector and may require a pull-up resistor; 28 VDC max, 200 mA max. A logic level high turns on the transistor and creates a current path to ground.

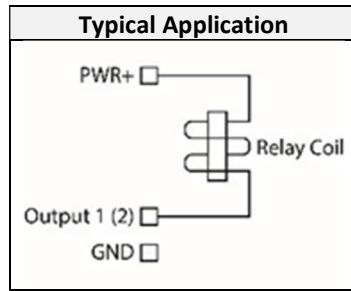
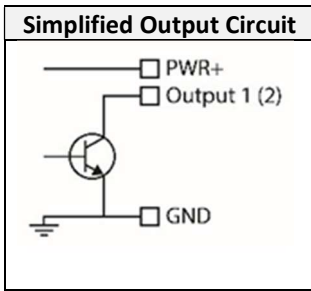

7. RS-232/Telnet Bidirectional ASCII Serial Communication Protocol

The IP-DXL Display Control Center full duplex RS-232/Telnet protocol is available for configuration and status monitoring. This protocol is not used for display control. All commands are sent as ASCII strings. No delays between characters or commands are required, as data is interrupt driven and buffered.

Communications parameters are 1200 to 230,400 baud, 8 data bits, no parity, and 1 stop bit. Factory default is 19,200 baud. All settings are saved to NVRAM in the decoder. The RS-232 port will accept non-standard control such as voltage that swings from 0 to +5 VDC, commonly found when IR ports are used to send RS-232 commands.

The same commands can be sent over IP Telnet (up to two sessions). The default Telnet port is 23.

General Protocol Specifications

Characters in command strings to the IP-DXL are common ASCII keyboard characters. Command strings sent to the ICE-HE-DXL begin with the ASCII > (greater than symbol) as an 'Attention' character and end with carriage return - ASCII CR, Hex \$0D, or keyboard Enter - as an 'End-of-command' character.

Responses from the IP-DXL begin with the ASCII < (less than symbol) as an 'Attention' character and end with a carriage return followed by a line feed - ASCII LF or Hex \$0A as an 'End-of-command' character.

A carriage return is required at the end of each command and is assumed in all examples.

Command String Structure

[Attention] [Command] (Parameters) [Return]

Attention Single character (>) starts the string

Command A two-character command

Parameters Added attributes to some commands

Return A carriage return ends the command string. ASCII CR, Hex \$0D, or keyboard 'Enter' may be used in programming. For simplicity, the programming examples in the manual will not show the 'CR'.

Command and Status Response

Commands can be sent back-to-back at any time without any delay. To allow for rapid, multiple commands, status responses are intentionally delayed by about 125 mS, sending the current status in response to control commands or user actions.

String Example

The example below is a command to set the subnet mask followed by the response string.

```
>IM=255.255.254.000
```

```
<$MAC=0014C816603C IP=192.168.1.251 IG=192.168.0.1 IM=255.255.254.000 IY=1
```

8. Bidirectional Serial Commands

Code	Function	Operation
Front Panel		
M0=	LCD Backlight	Sets LCD display backlight brightness 0-9
M1=	LCD Contrast	Sets LCD display contrast 0-8
S4=	Set Front Panel Lockout Mode	0=None 1=Setup Press Select and Right key to unlock temporarily

Code	Function	Operation
Network Setup		
IP=	Sets IP Address	IP=xxx.xxx.xxx.xxx Defines IP address, then returns status. IP returns the current MAC address, current IP address, subnet mask, and gateway. Response example : \$MAC=0014C816001B IP=192.168.001.251S IG=192.168.001.001 IM=255.255.255.000 IY=1. S or D at end of IP indicates DHCP or Static address. 000.000.000.000 indicates DHCP, but no DHCP server detected.
IM=	Subnet Mask	IM=xxx.xxx.xxx.xxx. Defines subnet mask. IM returns the current MAC address, current IP address, subnet mask, and gateway. Response example : \$MAC=0014C816001B IP=192.168.001.251S IG=192.168.001.001 IM=255.255.255.000 IY=1. S or D at end of IP indicates DHCP or Static address. 000.000.000.000 indicates DHCP, but no DHCP server detected.
IG=	Default Gateway	IG=xxx.xxx.xxx.xxx. Defines default gateway. IG returns the current MAC address, current IP address, subnet mask, and gateway. Response example : \$MAC=0014C816001B IP=192.168.001.251S IG=192.168.001.001 IM=255.255.255.000 IY=1. S or D at end of IP indicates DHCP or Static address. 000.000.000.000 indicates DHCP, but no DHCP server detected.
IY=	IP Address Mode	1=Static 2=DHCP
MC	MAC Address	Returns the MAC address
IX=	Telnet Port	IX=xxxxx Defines Telnet port
Serial Communication		
EN	Echo On	Echo On This command is not available for Telnet. Enable local echo in the terminal program.
EF	Echo Off	Echo Off
RS=	Baud Rate	1=2400 4=19.2K (Default) 2=4800 5=38.4K 3=9600 6=115.2K
Miscellaneous Commands		
NW=	Set Name	Sets the IP-DXL name. Limited to 20 characters.
NM	Get Name	Returns the IP-DXL name.
ID	ID	Returns the product model and application firmware version.
IB	Bootloader	Returns the bootloader firmware version.
HR	Hardware	Returns the hardware revision.
Z!	Reload factory default settings	Reconfigures unit for all factory default settings. IP address will not revert to default until after a Z] command or power cycle.
Z]	Reboot	Emulates a reboot from a hard power cycle.
I/O Port		
PS=	Set Output Pin	0=Out 1 Low, Out 2 Low 1=Out 1 High, Out 2 Low 2=Out 1 Low, Out 2 High 3=Out 1 High, Out 2 High
PG	Get Input Pin Status	0=In 1 Low, In 2 Low 1=In 1 High, In 2 Low 2=In 1 Low, In 2 High 3=In 1 High, In 2 High

9. iCC-Net Control Overview

iCC-Net is a unique and proprietary control command protocol from Contemporary Research for sending one-way control commands to display controllers, HDTV tuner/controllers, IPTV decoder/controllers, and HDTV tuners over new or existing video distribution infrastructure. Separate dedicated control wiring for each component from a central control system processor is not required. The user will be able to control the content on the displays via channel commands as well as volume and power.

The control data is delivered from the display control center over the RF distribution system along with the source channels or over the same Ethernet network as the source IPTV channels. The IP-DXL Display Control Center supports Ethernet control data delivery. The ICE-HE-DXL Display Control Center (not covered in this manual) supports delivery of the control data over RF and/or Ethernet.

The structure of the iCC-Net protocol command strings allows for independent control of large numbers of display controllers, HDTV tuner/controllers, IPTV decoder/controllers, and HDTV tuners. Each iCC-Net device will be assigned a unique display device number. As the command strings are broadcast to all devices on the distribution network, a device will only respond when it receives a string with a device number value that matches its configured device number. All other devices will ignore the command string.

10. Building an IPTV Based Control System

The IPTV based system will comprise of a control system interface to execute the commands, an IP-DXL Display Control Center, and any combination of IPTV decoder/controllers and tuners.

The control system requires a control system interface to execute the commands. The control system interface can be any of the following listed below.

- Display Express Server PC
- Display Express Lite web pages embedded in the IP-DXL or ICE-HE-DXL
- Third-party control processor

The IP-DXL Display Control Center is required to process and validate the iCC-Net data from the control system and format it to be broadcast into the IPTV network.

IPTV decoder/controllers are utilized to perform two functions. The units are full featured IPTV decoders used for receiving and decoding streaming IPTV content. The units also receive and respond to the iCC-Net data and process it for power, channel selection, volume, and display control. The decoder/controllers include the following listed below.

- QIP-D decoder/controller with RS-232 serial or HDMI CEC control of video displays
- QIP-DVX decoder/controller with IR, RS-232 serial, or HDMI CEC control of video displays

The compatible tuners can respond to the iCC-Net control commands for power, channel, volume, and other tuner related functions. The compatible tuners are listed below.

- 232-ATSC 4K HDTV tuner with HDMI CEC control of video displays
- ATSC-SDI 4i HDTV tuner

All components are required to be on the same subnet of the LAN. The control commands from the IP-DXL are sent as UDP directed broadcast data packets. The IP-DXL will use its configured IP subnet and subnet mask to calculate the directed broadcast address.

Refer to the product manual for the decoder/controller or HDTV tuner for instructions for setting the unit's display device number.

11. Compatible IPTV Control System Components

Display Express Server PC

The Display Express Server PC may be used as the control system interface just as in the RF control system. The Display Express Server PC hosts a web server. Users can log into the web server either locally or remotely using a web browser to access the control pages. The Display Express Server PC connects to the IP-DXL via RS-232 serial port, USB virtual com port, or via Ethernet TCP port 2728.

- Independent control of over 4000 displays
- Displays may be controlled as individual units, as defined groups, as zones, or as all
- Supports hundreds of source channels
- Supports multiple schedules
- Supports control presets and macro presets
- Allows for multiple users with unique customizable control pages and privileges
- Allows forwarding of custom strings to RS-232 controlled displays for advanced control
- Emergency alert presets may be manually or externally triggered

Display Express Lite

Display Express Lite is a web-based software application that is hosted in the IP-DXL Display Control Center and can be accessed by any device with an internet browser. The Display Express Lite web pages are accessed by entering the IP address of the IP-DXL in the browser's address bar. Display Express Lite by default will send the iCC-Net control commands via UDP broadcast data packets.

- Simplified control of display power, channel, and volume
- Control for up to 128 displays
- Displays may be controlled as individual units, as defined groups, or as all
- Supports selection of up to 32 source channels
- Basic power/channel scheduling

Third-Party Control System

A third-party control system may be used as the control system interface. The control system processor may connect to the IP-DXL Display Control Center via RS-232 serial port, USB virtual com port, or via Ethernet TCP port 2728.

QIP-D IPTV Decoder/Controller

The QIP-D is a combination IPTV decoder/controller. The unit is a full functioned MPEG-TS IPTV decoder equipped with a display controller.

- Receives ICC-Net IP commands
- RS-232 serial port or HDMI CEC for display control
- Contains RS-232 protocols for many common makes and models of flat panel displays and video projectors in on board memory
- RS-232 display type selectable using on-screen communication menu, web page, command from the IP-DXL or ICE-HE-DXL front panel, RS-232 serial command via serial port or Telnet
- HDMI CEC configurable using on-screen communication menu, web page, or RS-232 command via serial port or Telnet
- Display device number assigned using on-screen communication menu, web page, or RS-232 command via serial port or Telnet

QIP-DVX IPTV Decoder/Controller

The QIP-DVX is a combination IPTV decoder/controller. The unit is a full functioned MPEG-TS IPTV decoder equipped with a display controller.

- Receives ICC-Net IP commands
- RS-232 serial port, IR output, or HDMI CEC for display control
- Contains RS-232 protocols for many common makes and models of flat panel displays and video projectors in on board memory
- RS-232 display type selectable using on-screen communication menu, web page, command from the IP-DXL or ICE-HE-DXL front panel, RS-232 command via serial port or Telnet
- Contains IR libraries for many common makes and models of flat panel displays and video projectors in on board memory
- IR display type selectable using on-screen communication menu, command from the IP-DXL front panel, or RS-232 command via serial port or Telnet
- I/O and S/PDIF optical inputs for display power sense
- HDMI CEC configurable using on-screen communication menu, web page, or RS-232 serial command via serial port or Telnet
- Display device number assigned using on-screen communication menu, web page, or RS-232 command via serial port or Telnet

232-ATSC 4K HDTV Tuner

The 232-ATSC 4K is a full featured HDTV tuner. Although it cannot be used to receive IPTV streams, it can accept iCC-Net protocol IP commands on UDP port 31934.

- Receives ICC-Net IP commands
- Responds to commands for power, channel, volume, and other tuner related functions
- Display device number assigned using front panel menu or web page
- Supports HDMI CEC for display power control

ATSC-SDI 4i HDTV Tuner

The ATSC-SDI 4i is a full featured HDTV tuner with SDI output. Although it cannot be used to receive IPTV streams, it can accept iCC-Net protocol IP commands on UDP port 31934.

- Receives ICC-Net IP commands
- Responds to commands for power, channel, volume, and other tuner related functions
- Display device number assigned using front panel menu or web page

12. IPTV System Control Data Flow Examples

iCC-Net Control Data Flow with IPTV System Using Display Express Lite

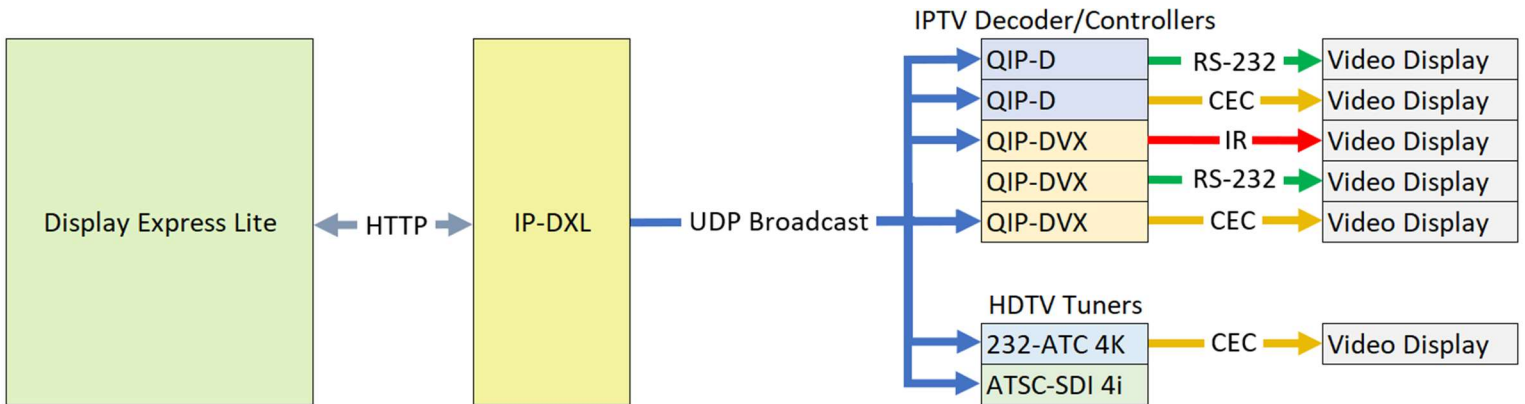

iCC-Net Control Data Flow with IPTV System Using Display Express

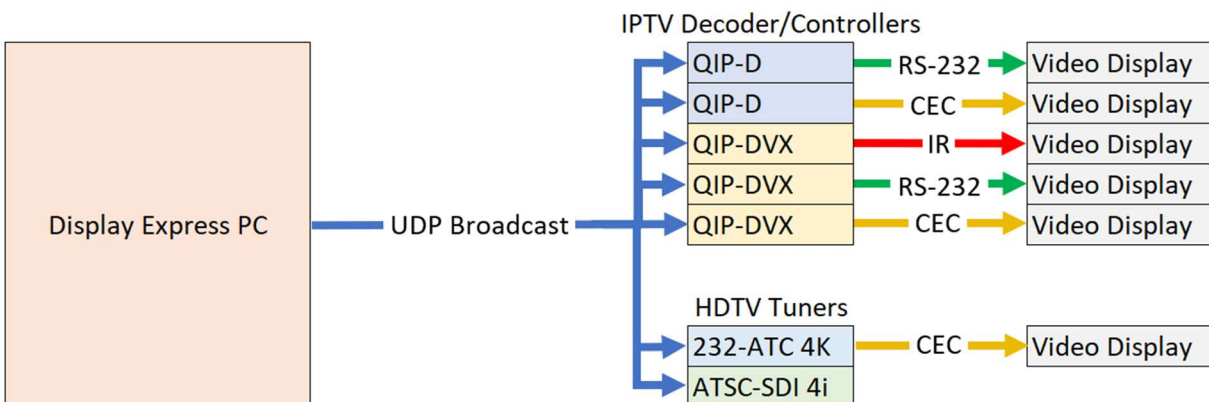

iCC-Net Control Data Flow with RF System Using Third-Party Control

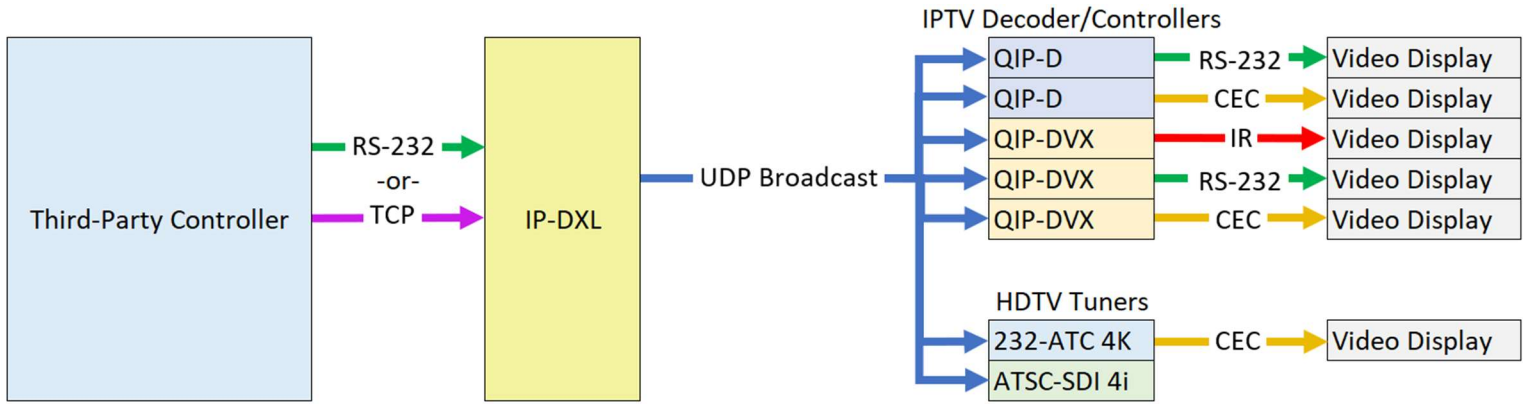

13. iCC-Net Display Control Protocol

The iCC-Net command string includes the display device number, the command, and command parameters if required.

Display Device Numbers

A unique display device number from 1 to 4094 is assigned to each TV controller, tuner controller, QIP-D decoder/controller, QIP-DVX decoder/controller, or tuner to which control commands are addressed. The displays are organized into 16 zones of up to 255 devices each.

The Zone/Unit concept is used with Display Express, Display Express Lite, and when writing command strings for third-party control systems. Display Express Lite is limited to 128 display devices in zone 1. Unit numbers are restricted to the range of 1 to 128 corresponding to display device numbers 257 to 384.

The display device number is represented in the iCC-Net command string by the zone number and the unit number. The hex equivalent of the zone number and the unit number is equal to the hex equivalent of the display device number.

Example:

Zone 3 = hex 03

Unit 201 = hex C9

Display Device 969 = Hex 03 C9

The device number can be calculated in decimal using the formula '(zone number x 256) + unit number = display device number'.

All display controllers in a zone will respond to a command sent to unit number 0. All display controllers will respond to a command sent to Zone 15, Unit 255.

Zone #	Zone x 256	Unit #	Display Device #
0	0	1-255	1-255
1	256	1-255	257-511
2	512	1-255	513-767
3	768	1-255	769-1023
4	1024	1-255	1025-1279
5	1280	1-255	1281-1535
6	1536	1-255	1537-1791
7	1792	1-255	1793-2047
8	2048	1-255	2049-2303
9	2304	1-255	2305-2559
10	2560	1-255	2561-2815
11	2816	1-255	2817-3071
12	3072	1-255	3073-3327
13	3328	1-255	3329-3583
14	3584	1-255	3585-3839
15	3840	1-254	3841-4094
All Zones	4095		

Command String Protocol

“\$A5,<dh>,<dl>,<ncb>,<cmd1>,<parameter>[<cmdN>]”

\$A5	Starts the command
<dh>	The zone or high order byte of the display device
<dl>	The unit or low order byte of the display device (0 for global zone)
<ncb>	The number of command bytes to follow
<cmd1>	The first two-character command
<parameter>	Command parameters (not used in all commands)
[<cmdN>]	Multiple commands can be concatenated, with byte count added to <ncb>

Characters in command strings are expressed in a combination of hex and ASCII characters. For clarity, the following protocol examples use the following conventions:

- Single-byte hex numbers are preceded by the ‘\$’ symbol.
- ASCII characters or strings are enclosed in single quotes.
- Numbers not marked as hex or ASCII are the decimal equivalent of a single hex byte.
- Parameters shown in < > brackets are single byte.
- A series of multiple commands or parameters are set apart by [] brackets.
- Commas separate the bytes, but they are not part of the protocol.
- Double quotes enclose the command string, but they are not part of the protocol.

A Decimal/ASCII/Hex conversion chart may be found at www.asciitable.com.

String Format

Every software application has a different denotation for handling hex, ASCII, and decimal formats. The examples in this manual are in AMX format, which is understood by many in the control industry:

- Hex values begin with a dollar (\$) symbol
- ASCII values are enclosed in single quotes
- Decimal values are shown as normal

When planning to use a mixed-format structure for commands, convert the symbols to the types required by your specific software application. For example, a **Tune Channel 12-3** command to display device 280 could be shown several ways:

- AMX Mixed Format = “\$A5,1,24,5,'TH',2,12,3”
- AMX Hex Format “\$A5 \$01 \$18 \$05 \$54 \$48 \$02 \$0C \$03”
- Standard Hex (no denotation) = A5 01 18 05 54 48 02 0C 03
- Crestron Hex Format = \0xA5\0x01\0x18\0x05\0x54\0x48\0x02\0x0C\0x03
- RTI = Select port, Hex mode, enter A5 01 18 05 54 48 02 0C 03 - Note that when you go back to normal editing mode, the app inserts a \x before each Hex character.

Go to www.asciitable.com for a handy Decimal/ASCII/Hex conversion chart.

14. Common iCC-Net Commands

The commands listed in the following table apply to all display controllers, tuner/controllers, IPTV decoder/controllers, and HDTV tuners. Each display controller, tuner/controller and IPTV decoder/controller has additional commands. Refer to the product manual for each unit for a more complete list of available commands.

Code	Function	Operation
Power		
P1	Power On	"\$A5,<dh>,<dl>,2,'P1'" (6 bytes)
P0	Power Off	"\$A5,<dh>,<dl>,2,'P0'" (6 bytes)
Channel Selection		
TH=	Set Digital Channel	<p>"\$A5,<dh>,<dl>,5,'TH',<H1>,<Major>,<Minor>" (9 bytes) Sets digital channel with one-part virtual channel numbers and two-part channel numbers up to 255-255</p> <p><H1> Tuning Style 0=No Change in tuning style 1=Five digit one-part channel (Major=high byte, Minor=low byte) Formula: (high byte x 256) + low byte = channel number 2=Two-part virtual channel number (Major-Minor) 3=Two-part physical channel number (Major-Minor)</p> <p><i>Examples:</i> "\$A5,1,4,5,'TH',2,2,3" Device 260, virtual channel 2-3 "\$A5,1,4,5,'TH',1,1,69" Device 260, channel 325 (256+69)</p>
TJ=	Set Digital Channel	<p>"\$A5,<dh>,<dl>,6,'TJ',<Major high>,<Major low>,<Minor high>,<Minor low>" (10 bytes) Sets digital channel with two-part virtual channel numbers up to 999-999</p> <p>Formula: (high byte x 256) + low byte = channel number</p> <p><i>Example:</i> "\$A5,2,44,6,'TJ',1,40,0,1" Device 580, channel 296-1</p>
Audio		
VL=	Volume	<p>"\$A5,<dh>,<dl>,3,'VL',<Level>" (7 bytes) Sets volume in 64 steps 0 - 63.</p> <p>For ICC1-IRX, volume will ramp to lowest setting, then ramp up to specified level.</p>

15. Web Page Access

The IP-DXL has on-board web pages for control and configuration. The web pages may be accessed from a web browser by entering the unit's IP address in the browser's address field. The unit's IP address may be viewed on the front panel LCD display by holding the **Setup** button. The web pages may also be accessed through CR Toolbox. Double-clicking on the IP-DXL unit in the equipment list will launch the default web browser and navigate to the IP-DXL.

The on-board web pages will be password protected by default.

Three modes of protection are available.

- Password will be required to access all web pages (default).
- Free access to the Display Express Lite Control web page, but a password will be required to access all other web pages.
- Free access to all web pages.

For increased security when password protection of the web pages is desired, it is recommended to lock out the **Setup** button on the front panel of the IP-DXL.

Default Password

The default password is based on the last six characters of the unit's MAC address. The MAC address may be found on the SN/MAC sticker on the rear of the unit. The MAC address may also be displayed in the front panel LCD setup menu under **Network**. Follow the steps below to display the MAC address.

- Press **Setup** on the front panel.
- Press **Left** or **Right** to until **Network** is displayed, then press **Select**.
- Press **Up** or **Down** until the MAC address is displayed.

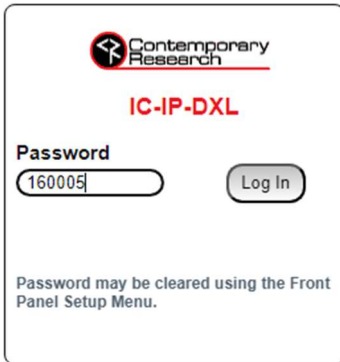

When the web page is first accessed, the browser will be directed to the login page. Enter the last six characters of the MAC address in the password field, then click the **Log In** button. The characters should be entered with no punctuation or spaces. Letters should be entered as upper case. i.e.: 16021A

16. Display Express Lite Control Software

The Display Express Lite display control software is comprised of the Control and Schedule web pages.

The Control web page allows for manual control of a TV, a Group, or multiple selected TVs. The control function can be a channel selection, volume, or power command. Selecting the Clear button will clear the selected Groups or TVs.

The Schedule web page allows for a simple daily schedule for automation of TV power on, channel, and power off.

Display Express Lite supports control of up to 128 of any combination of display controllers, tuner/controllers, IPTV decoder/controllers, or tuners. The display controllers, tuner/controllers, IPTV decoder/controllers, or tuners are represented by the TV buttons. The user can select from up to 32 source channels as well as control volume and power for the displays. For convenience, global All On and All Off buttons are available.

The default configuration has 20 TVs assigned to one group and 8 source channels.

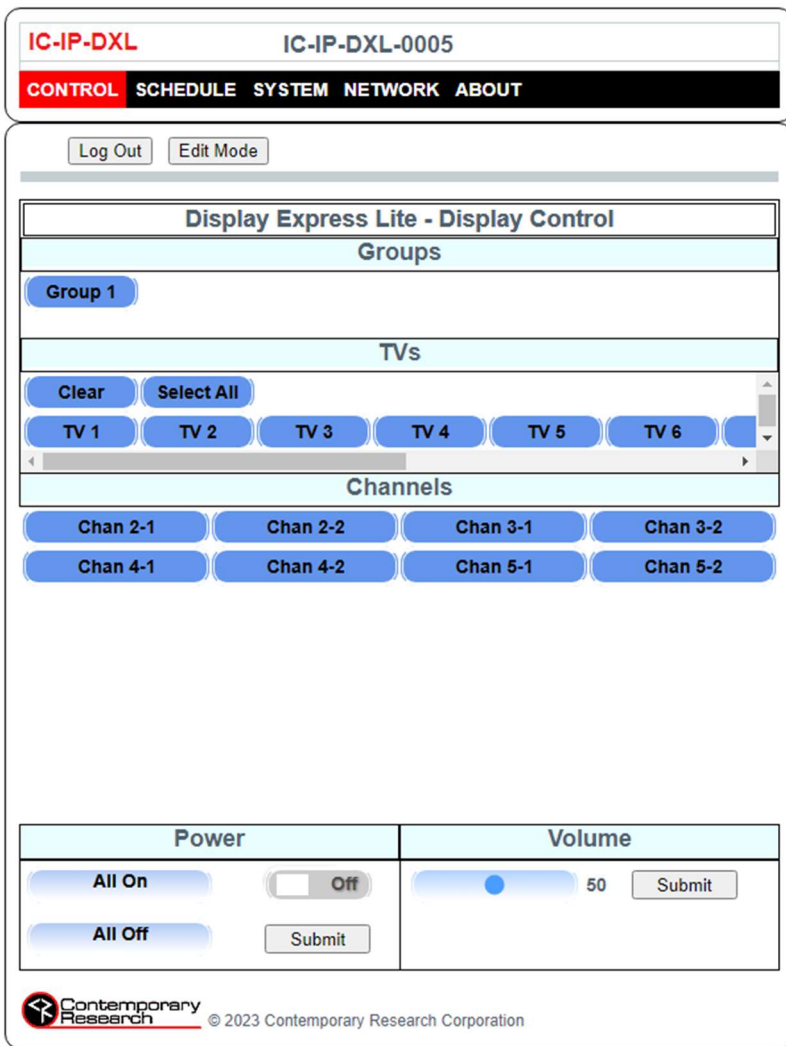

Operating Display Express Lite

Operation of the Display Express Lite Control page is very simple and intuitive.

- Select a TV, multiple TVs, or a group of TVs.
- Select a channel button or the Submit button for volume or power functions.
- Power All On or All Off are global and independent of the TV or TVs selected.

Configuring Display Express Lite

To configure Display Express Lite, the web page will need to set to Edit Mode. Edit Mode allows for the Group, TV, and Channel buttons to be edited, renamed, added, and deleted.

To enter/exit Edit Mode, click on the **Edit Mode** button. The **Edit Mode** button will turn red when in edit mode. Click on any TV or Channel button to edit, add, or delete. Group buttons are automatically added or deleted when the first TV is added to a group or the last TV is removed from a group.

TVs

For IPTV applications, the TV buttons correspond to the QIP-D or DVX decoder/controllers. TVs may be added, deleted, and assigned to Groups. Each TV button may be renamed. The Label field supports up to ten characters. Each TV button will be assigned an address. The address will match the display device number of the display controller, tuner/controller, IPTV decoder/controller, or tuner to be controlled by that button. The address is expressed as a three-digit number with a range from 257 to 384. For display controllers and tuner controllers that are configured using a Zone and Unit number, the address corresponds to Unit numbers 1 to 128 in Zone 1.

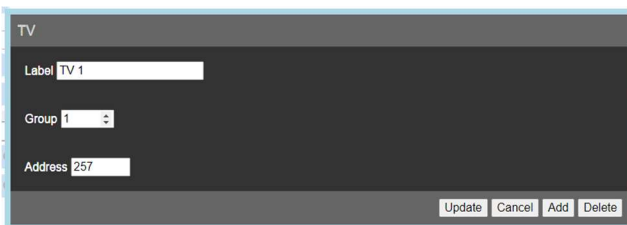

Groups

Individual TVs must be assigned to a group. A minimum of one group is required. Each Group button may be renamed. The Label field supports up to ten characters. To create a new group, just assign a TV to a group number that is not used. To delete a group, reassign all TVs in that group to another group.

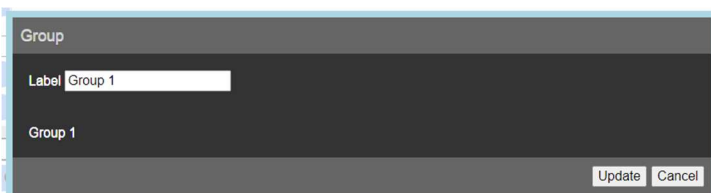

Channels

Channels may be added or deleted. Each Channel button may be renamed. The Label field supports up to ten characters. To add a channel, select an existing channel, modify it with the new channel settings and click **Add**. The new channel will be added in the same column as the initial channel that was selected for modification.

Display Express Lite will automatically format the iCC-Net channel command string with the correct tuning style based on the settings entered in the Edit Channel window. Special 0-xxx two-part channel commands are supported for display input selection, captions, and other functions.

Channel Type	Major #	Minor #
Two-part Digital	<0-999>	<1-999>
One-part Digital	<1-9999>	Leave Blank
Analog	<2-135>	<0>

Schedule

The Schedule page allows for basic power on/off and channel events to be scheduled on a daily basis.

Day	En	TV/Group	Channel	Time On	Time Off
Mon	<input checked="" type="checkbox"/>	All	Chan 2-1	08:00 AM	06:00 PM
Tue	<input checked="" type="checkbox"/>	All	Chan 2-1	08:00 AM	06:00 PM
Wed	<input checked="" type="checkbox"/>	All	Chan 2-1	08:00 AM	06:00 PM
Thu	<input checked="" type="checkbox"/>	All	Chan 2-1	08:00 AM	06:00 PM
Fri	<input checked="" type="checkbox"/>	All	Chan 2-1	08:00 AM	06:00 PM
Sat	<input checked="" type="checkbox"/>	Group 1	Chan 4-1	09:00 AM	01:00 PM
Sun	<input type="checkbox"/>	All	No Change	12:00 AM	12:00 AM

Weekday Schedule:

DXL System Time: Tue 12/05/2023 04:36 PM

Custom Time:

Use Network Time:

© 2023 Contemporary Research Corporation

17. RKU Universal Rack Mount Kit

All Contemporary Research rack-mountable products will now include a Universal Rack Mounting Kit (RKU). The RKU will allow for mounting of a single unit or two units side-by-side in a 19" rack. One Universal Rack Mounting Kit will be included with the purchase of each product and will include the following parts:

- Two (2) Short Rack Ears
- One (1) Long Rack Ear
- One (1) Center Mount Tie-bar
- Six (6) 8-32 x 1/4" Screws
- Two (2) 4-40 x 3/16" Screws

Two Across Mounting

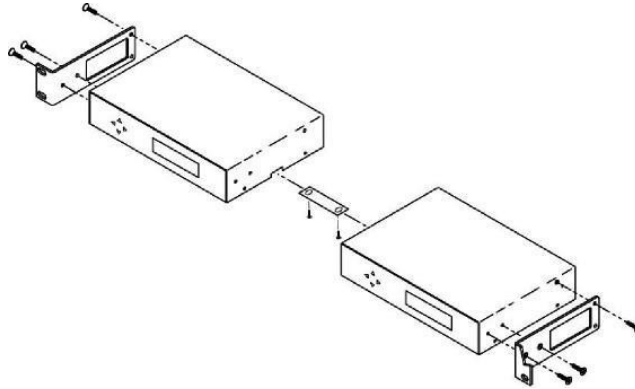

When mounting two components in one RU rack space, use the two short rack ears and the tie bar assembly.

Note that older versions of the QDA4-45 and QCA9-33 have solid side panels and should not be mounted next to actively cooled components with the ventilation holes, as that will block airflow.

1. Check that the enclosures have the tie bar slot.
2. Slide the included tie bar into the side of one unit and attach with one included 4-40 x 3/16" screw, but do not tighten.
3. Slide the other unit into the tie bar, attach with the second 4-40 x 3/16" screw, and tighten both screws.
4. Add the rack mounts to the sides using the six 8-32 x 1/4" screws.

Single Unit Rack Mounting

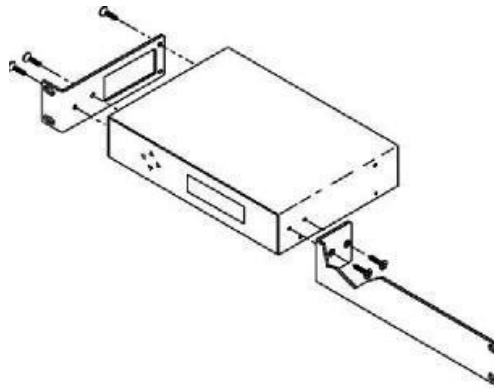

Attach a long and short rack ear to each side at the front of the unit, using five of the 8-32 x 1/4" screws.

18. Specifications

Physical

Size (HWD): 8.5" [216 mm] wide x 1.73" [44 mm] high (1 RU) x 8.0" [203 mm] deep

Weight: 1.88 lbs [854 g]

Enclosure: Aluminum with black powder coat paint

Mounting: 1 RU Rack mounting for one- or two-units side-by-side (RKU, RK1, RK2EZ)

Cooling: Active cooling not required for normal applications.

Front Panel



Display: Text display, white text on blue LCD

Control: Setup, Select, and Up/Down/Left Right navigation buttons

USB: Mini USB-B virtual com port for control, configuration, and firmware updates

Back Panel

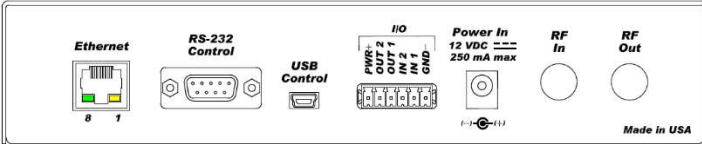

Ethernet: RJ-45 10/100 Ethernet connector for Web page access, Telnet, UDP control, and IPTV Streaming

RS-232: DB-9 male, RS-232 data link to control system, 1200 to 115.2K baud (19.2K default), 8 data bits, no parity, 1 stop bit

USB Control: Mini USB-B virtual com port for control, configuration, and firmware updates

I/O: Logic control port 6-pin captive screw terminal

- | | |
|----------|--------------------------------------------------------------------|
| 1 – PWR+ | Power, 12 VDC, 250 mA max (using the included 500 mA power supply) |
| 2 – OUT2 | Output 2 |
| 3 – OUT1 | Output 1 |
| 4 – IN2 | Input 2 |
| 5 – IN1 | Input 1 |
| 6 – GND- | Ground |

Power In: 2.1 mm coaxial jack (inside center conductor positive), 1.1 A maximum, 11 to 18 VDC, 12 VDC typical, 250 mA maximum, 45 BTU

Includes

PS12-500 Power Supply, Input: 100 to 240 VAC autosensing, Output 500 mA maximum, 12 VDC (5400-001)

RKU Universal Rack Kit

Options

RK1 Single Rack Kit, 1 RU (5008-001)

RK2EZ Dual Rack Kit, 1 RU (5008-015)

CC-COM-B RS-232 Null Modem Cable (5061-003)

19. Safety Instructions and Warranty

Read before operating equipment.

- **Cleaning** - Unplug this product from the wall outlet before cleaning. Do not use liquid cleaners or aerosol cleaners. Use a damp cloth for cleaning.
- **Power Sources** - Use supplied or equivalent UL/CSA approved low voltage DC plug-in transformer.
- **Outdoor Antenna Grounding** - If you connect an outside antenna or cable system to the product, be sure the antenna or cable system is grounded so as to provide some protection against voltage surges and built-up static charges. Section 810 of the National Electrical Code, ANSI/NFPA No. 70, provides information with respect to proper grounding of the mast and supporting structure, grounding of the lead-in wire to an antenna discharge unit, size of grounding conductors, location of antenna discharge unit, connection to grounding electrodes, and requirements for the grounding electrode.
- **Lightning** - Avoid installation or reconfiguration of wiring during lightning activity.
- **Power Lines** - Do not locate an outside antenna system near overhead power lines or other electric light or power circuits or where it can fall into such power lines or circuits. When installing an outside antenna system, refrain from touching such power lines or circuits, as contact with them might be fatal.
- **Overloading** - Do not overload wall outlets and extension cords as this can result in a risk of fire or electric shock.
- **Object and Liquid Entry** - Never push objects of any kind into this product through openings as they may touch dangerous voltage points or short out parts, resulting in a fire or electric shock. Never spill liquid of any kind on the product.
- **Servicing** - Do not attempt to service this product yourself as opening or removing covers may expose you to dangerous voltage or other hazards. Refer all servicing to qualified service personnel.
- **Damage Requiring Service** - Unplug this product from the wall outlet and refer servicing to qualified service personnel under the following conditions:
 - When the power supply cord or plug is damaged.
 - If liquid spills or objects fall into the product.
 - If the product is exposed to rain or water.
 - If the product does not operate normally by following the operating instructions. Adjust only those controls that are covered by the operating instructions. An improper adjustment of other controls may result in damage and will often require extensive work by a qualified technician to restore the product to its normal operation.
 - If the video product is dropped or the cabinet is damaged.
 - When the product exhibits a distinct change in performance, this indicates a need for service.
- **Heat** – This product should be situated away from heat sources such as radiators, heat registers, stoves, or other products (including amplifiers) that produce heat.

Note to CATV system installer: This reminder is provided to call CATV system installer's attention to Article 820-40 of the National Electrical Code (Section 54 of Canadian Electrical Code, Part I), that provides guidelines for proper grounding and, in particular, specifies that the cable ground shall be connected to the grounding system of the building as close to the point of cable entry as possible.

Warranty: Three (3) year limited warranty on all parts and labor for Contemporary Research manufactured products. Contemporary Research warrants its manufactured products against defects in materials and workmanship for a period of three years from the day of purchase by authorized dealer. If Contemporary Research receives notice of such defects during the warranty period; Contemporary Research, at its option, will repair or replace products that prove to be defective.

Exclusions: The above warranty shall not apply to defects resulting from improper or inadequate maintenance by the customer, customers applied software or interfacing, unauthorized modifications or misuse, mishandling, operation outside the normal environmental specifications for the product, use of the incorrect, modified or extended power supply, acts of God, weather, or improper site operation and maintenance. Please note Contemporary Research SSV-DX Display Express PC and Luxul Managed Switch products carry a six-month limited warranty.

Product Service: Contemporary Research will test, repair, or replace the product or products without charge if the unit is under warranty. If the product is out of warranty, Contemporary Research will test, and then repair the product or products. The parts and labor charge will be estimated by a technician and confirmed by the customer prior to repair. All components must be returned for testing as a complete unit. Contemporary Research will not accept responsibility for shipment after it has left the premises.

Technical Support: Contemporary Research technicians will determine and discuss with the customer the criteria for repair and/or replacement. Contemporary Research Technical Support can be contacted through one of the following resources: e-mail support at support@crwww.com or phone at: 972-931-2728

Return Material Authorization (RMA) Number: Before returning a product for repair or replacement, request an RMA from Contemporary Research's technical support. Provide tech support with a return phone number, e-mail address, shipping address, product serial numbers and original purchase order number. Describe the reason for repairs or returns as well as the date of purchase. See the General RMA Terms and Procedures section for more information. RMA's are valid for 30 days and will be issued to authorized Contemporary Research dealers only. End users must return products through authorized Contemporary Research dealers. Include the assigned RMA number in all correspondence with Contemporary Research. Write the assigned RMA number clearly on the shipping label of the box when returning the product.

Voided Warranty: The warranty does not apply if the original serial number has been removed or if the product has been disassembled or damaged through misuse, accident, acts of God, weather, modifications, use of incorrect, modified or extended power supply, or unauthorized repair.

Shipping and Handling: Contemporary Research will not pay for inbound shipping transportation or insurance charges or accept any responsibility for laws and ordinances from inbound transit. Contemporary Research will pay for outbound shipping, transportation, and insurance charges for all items under warranty, but will not assume responsibility for loss and/or damage by the outbound freight carrier. If the return shipment appears damaged, retain the original boxes and packing material for inspection by the carrier. Contact your carrier immediately.

Products not under Warranty: Payment arrangements are required before outbound shipment for all out of warranty products.

General RMA Terms and Procedures: RMA's are valid for 30 days and will be issued only to authorized Contemporary Research dealers only.

- End users must return products through authorized Contemporary Research dealers.
- Before a defective product can be authorized to send in for repair, it must first go through the troubleshooting process with a member of the Contemporary Research Technical Support team.
- Products authorized for repair must have a valid RMA (Return Material Authorization) number.
- Contemporary Research Technical Support will approve the issue of an RMA number.
- An RMA number is to be included in all correspondence with Contemporary Research.
- The RMA number must appear clearly on the shipping label when the product is returned.
- A packing slip must be included on the inside of the box with the RMA number listed and reason for RMA return.
- Products received at Contemporary Research that do not have a valid RMA number clearly marked on the outside of the shipping container may be refused and returned to sender.
- Boxes showing external damage will be refused and sent back to the sender regardless of the clearly marked RMA number and will remain the responsibility of the sender.

Advanced Replacement Policies: For Contemporary Research manufactured products, advance replacement will be provided for "out-of-the-box" failures up to thirty (30) days after the initial shipment of products.

Shipments of equipment that are refused upon attempted delivery, for any reason, are subject to restocking charges.



3220 Commander Drive, Suite 102

Carrollton, TX 75006

Ph. 888-972-2728

www.contemporaryresearch.com